

## FUEL BOWSER



## REFUEL IN THE FIELD ...

Our Fuel Bowser features a 2000 ltr fully bunded tank, with a 12v, 85 L/min pump positioned for easy access which is protected by a locking top panel. Also with lockable double back doors incorporating a 220 litre Adblue tank with pump and auto gun plus a storage shelf.

### Standard features

Both models feature mudguards, brakes, screw jack or shoe, LED lights, flow meter, number plate holder, 220 litre Adblue tank, 10 metre retractable hose with auto gun and rear storage compartment. The Standard Bowser is designed to be towed by a motor vehicle and the Agricultural Bowser by a tractor.



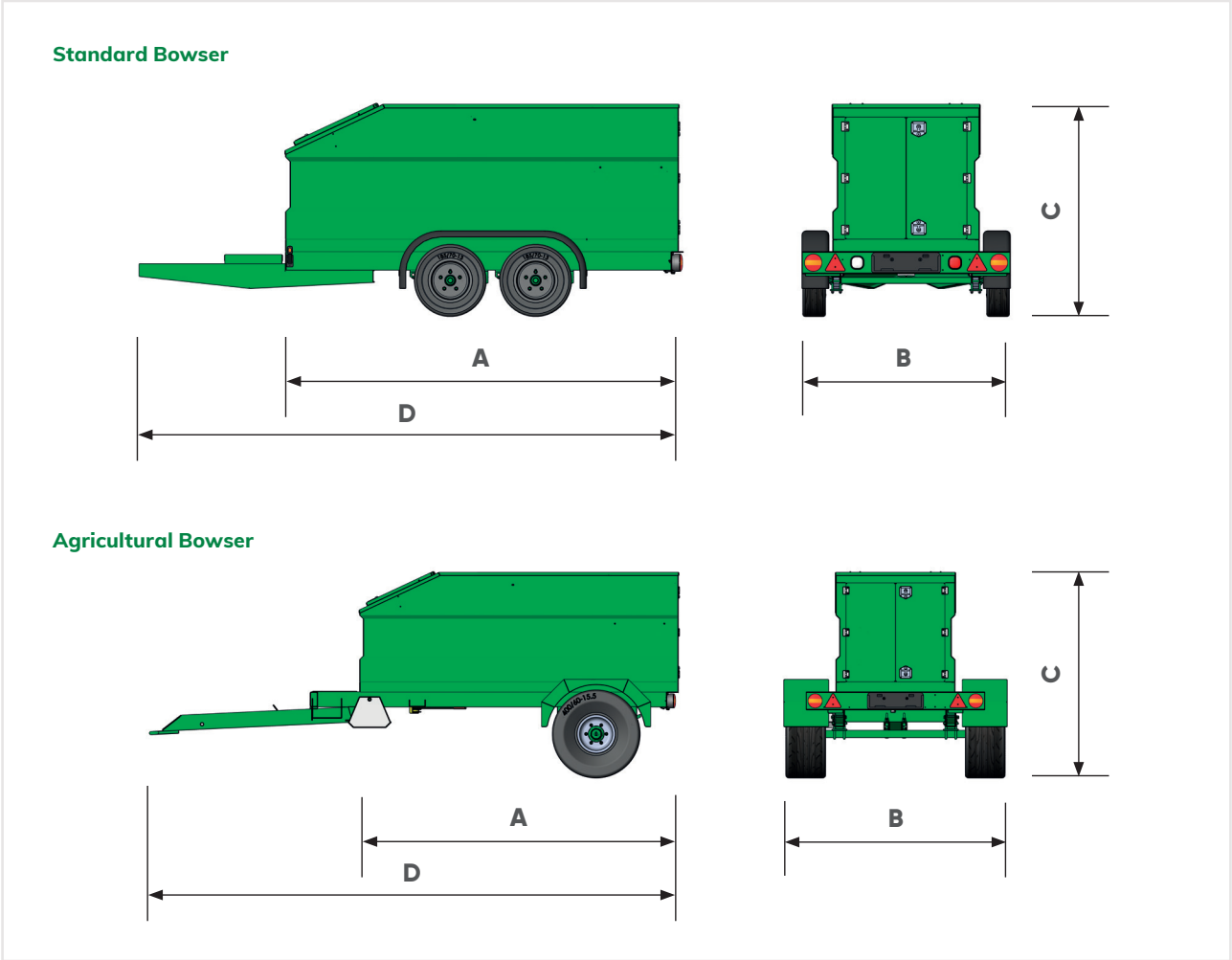

Model			Standard	Agricultural
<b>Dimensions</b>				
Body length	A	mm	3230	3230
Overall width	B	mm	1750	2260
Overall height	C	mm	1730	2050
Overall length	D	mm	4760	5330
<b>Misc.</b>				
Number of axles			2	1
Axle beam		mm/studs	50/5 Stud	70/6 Stud
Brake size			250 x 40	300 x 60
Brake option			Over run	Hydraulic
Tyre size			185/70 R13	400/60 x 15.5

**BAILEY TRAILERS LIMITED**

Pride Parkway, Sleaford, Lincolnshire NG34 8GL

+44 (0) 1529 303411 | sales@baileytrailers.co.uk | baileytrailers.co.uk